



Get extended growing times, taller crops and higher revenues from every field by using CountyTrac's new

HI-CROP DRIVELINE SYSTEM



INTRODUCING HI-CROP

High-clearance conversions for New Holland and Case IH tractors that improve all row-crop usages.



CountyTrac
AGRICULTURAL ENGINEERING

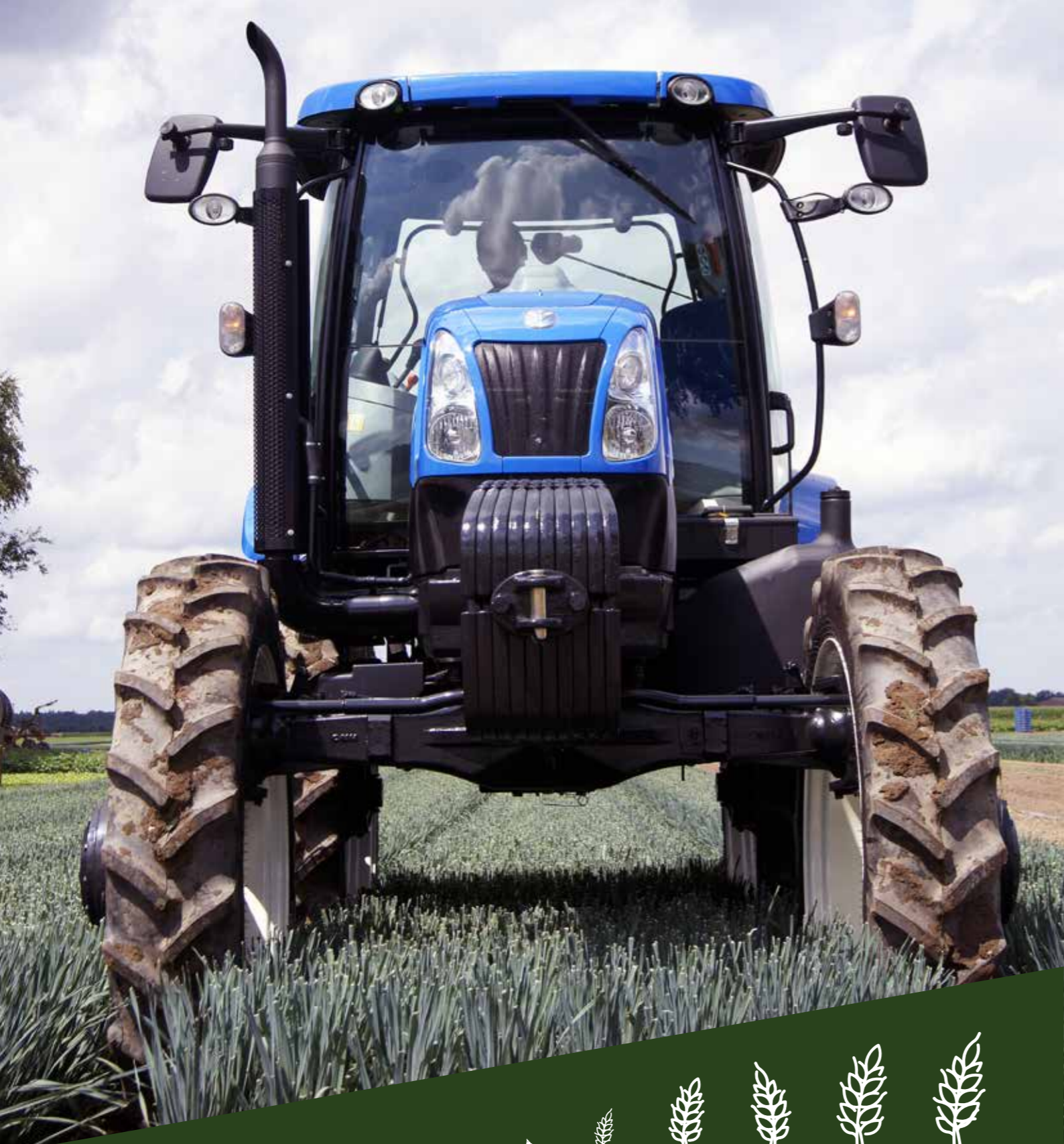

WELCOME TO HI-CROP

The Hi-Crop range of specialist driveline systems for tractors and agricultural vehicles is our flagship product in a range of agricultural design and engineering options offered by CountyTrac and parent company County.

Originally formed in 1929, 'County' is an innovative, vehicle-parts engineering company with decades of professional experience in vehicle builds and conversions - from six-wheel truck modifications and high-clearance tractors to complete drivetrains and all-wheel-drive systems for mass production.

'CountyTrac' is our dedicated, agricultural subdivision known by land owners worldwide.

All design and manufacturing is done here in the UK. We ship our products across the globe and can provide ongoing support - either directly or through our network of approved service partners.



Your vehicle is in safe hands as we enjoy long relationships with leading global tractor manufacturers Steyr, New Holland and Case IH.



County is a member of the MJAllen Group, a family-owned business based in the UK and with almost a century of expert engineering, driveline and automotive knowledge.

👉 countytrac.com [in /countytrac](https://www.linkedin.com/company/countytyrac)
🐦 [@countytyrac](https://twitter.com/countytyrac)

HI-CROP CAN EXTEND YOUR GROWTH WINDOW BY UP TO 18 MONTHS GIVING LARGER HARVESTS AND GREATER VALUE



TOTAL CUSTOMER CARE

We welcome individual customer enquiries and can work with a single landowner or a national supplier. Building good relationships is one of our core values and most of our orders come from customer referrals or repeat business - evidence that we are doing things right and putting the customer first.

FOUNDED IN 1929

Let us help you with our extensive knowledge from almost a century of company history that is rooted in agricultural engineering - backed by a professional team with over 75 years of experience.

WE GO BEYOND THE SALE

We undertake the planning, design and precise manufacture of all our custom equipment ourselves. This lets us cater for unique requirements and we welcome all customer challenges!

THE RIGHT FIT FOR YOU

All our systems can be supplied as complete kits or individual spare parts depending on your requirements and will always be compatibility approved for your chosen vehicle.

WHY HI-CROP?

Hi-Crop can almost double the clearance of your existing vehicle without compromising its versatility.

More CAD and technical drawings on our website

Standard axle centre line Hi-Crop axle centre line

60-INCH TRACK

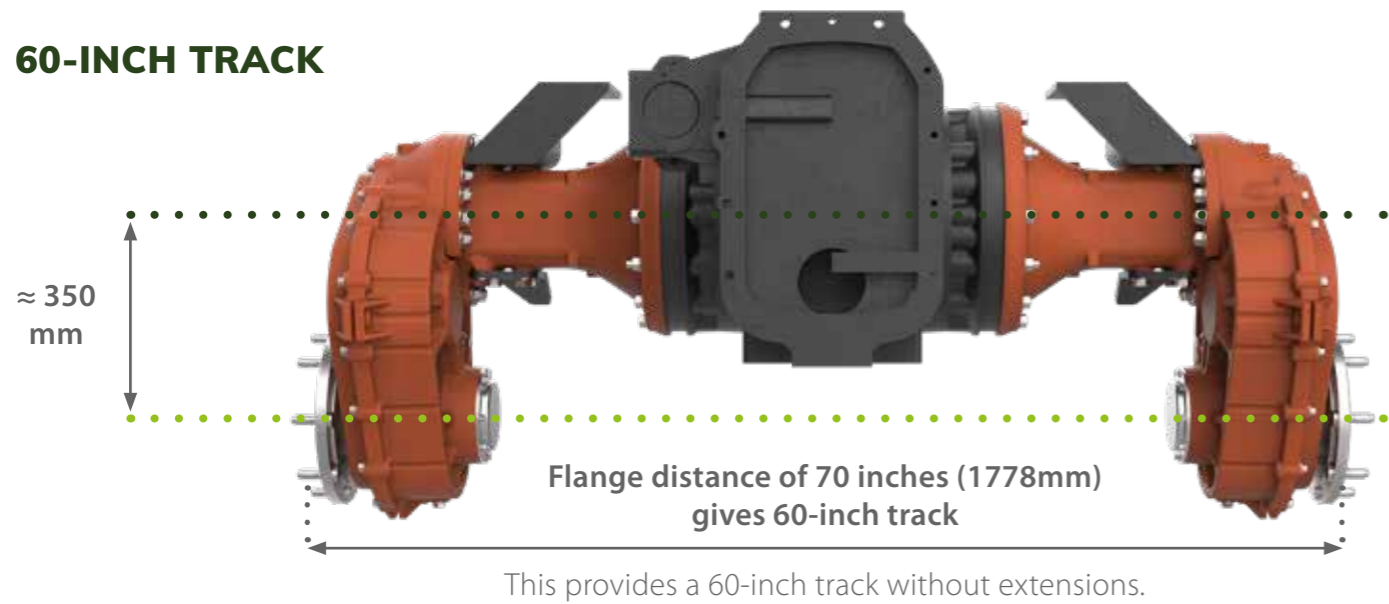

72 OR 80-INCH TRACKS

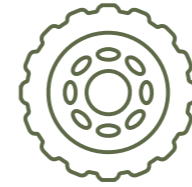
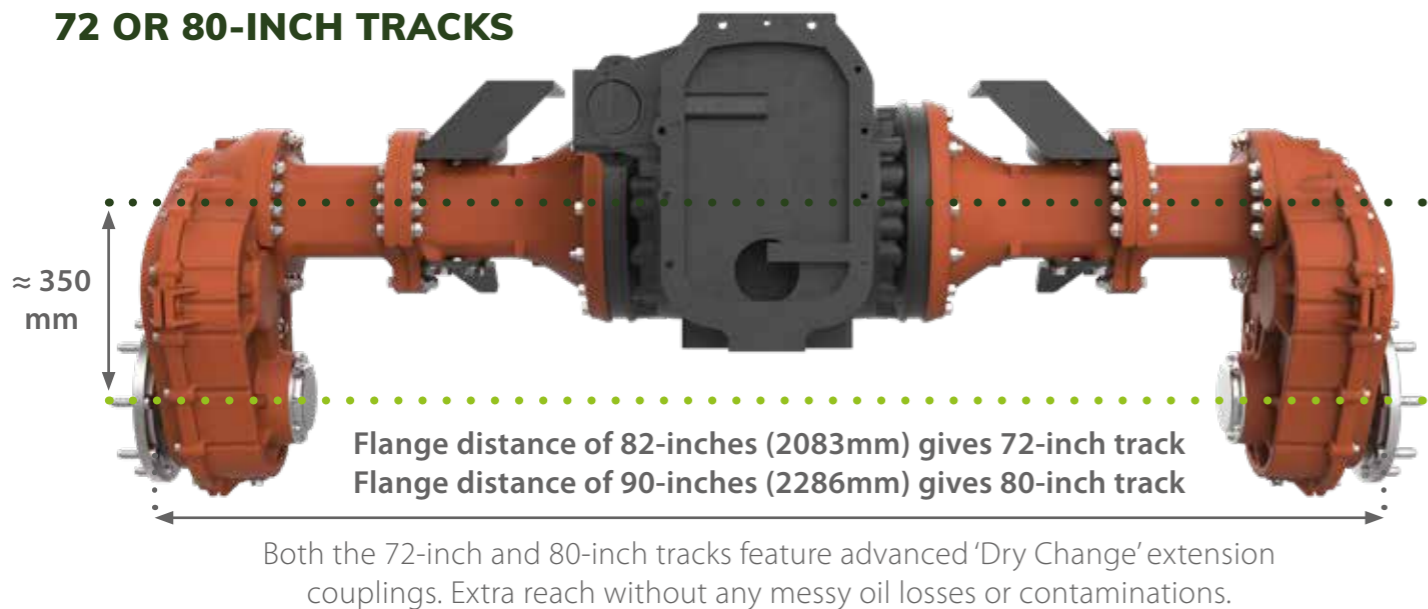

RAISE YOUR GAME

With class-leading tractor clearance whatever the ground conditions.

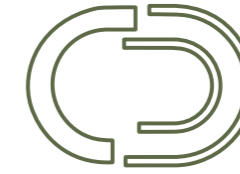

THE RIGHT TRACK

Choose from 60, 72 or 80 inches. Our conversion kits provide a track width to suit all types of planting.

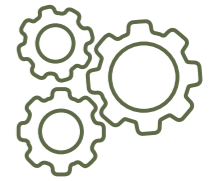

SUPER CREEP

Our advanced gearing allows super-slow creep speeds of just 0.09kph.



UK MANUFACTURED

Designed and built at our UK facility and shipped all across the world.



BRAND COMPATIBLE

Our kits are designed to work seamlessly with select Steyr, New Holland and Case IH tractors.



FULL WARRANTY

Cover for your original vehicle and the conversion kit. Hi-Crop won't affect your OEM warranty.



EXPERT ADVICE

We offer comprehensive pre-sales advice and ongoing care to all customers.



PREMIUM PROCESS

Every Hi-Crop kit goes through a rigorous multi-point check and is only dispatched with a 5-star rating.



DRY CHANGES

Change tracks to suit your work without any messy drain downs or costly oil changes.



ISO 9001 is an internationally recognized Quality Management System standard that allows us to monitor our business and implement powerful improvements. We design and build to the highest standards and are always improving our products, operations and services.



RIGHT FOR YOUR FARM

We build solutions for tractors from leading suppliers New Holland Agriculture and Case IH.



NEW HOLLAND AGRICULTURE

Offering a complete agricultural range to help manage all types of farms, livestock and crop growing since 1895.



CASE IH

Like CountyTrac, reliability and quality are at the heart of Case IH and their technological advancements represent more than 175 years of expertise in the industry.

We select the best tractor models from these leading manufacturers and design custom modifications to convert their existing drivetrains into our class-leading, high-clearance versions. We stay close to our preferred manufacturers and maintain a strong network of both dealers and suppliers. Whenever technological or ecological improvements are made, we review our modifications to ensure we are always offering the best option for your vehicle - from purchase or in service.

HI-CROP VEHICLE CHECKLIST

Vehicles of any age and condition can be converted for high-clearance, as long as these basics are met:

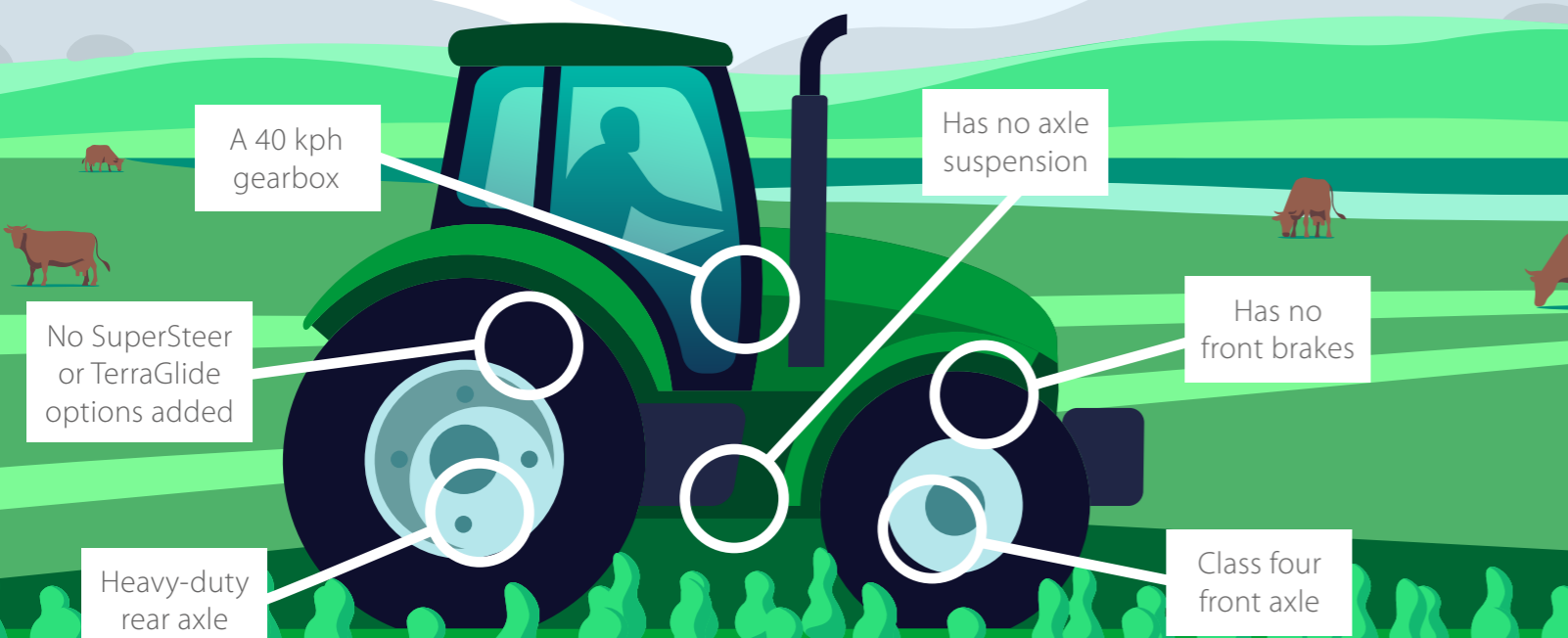

STEYR
Hi-Crop for Steyr now available!
Contact us!



NEW HOLLAND T6 - GAIN 88% MORE HEIGHT WITH HI-CROP

Model	UNMODIFIED		60" HI-CROP KIT		72" / 80" HI-CROP KIT	
	Weight	Clearance	Weight	Clearance	Weight	Clearance
145	5430	528	6139	995	6205 / 6246	995
155	5430	528	6139	995	6205 / 6246	995
160	5610	528	6319	995	6385 / 6426	995
165	5490	528	6199	995	6265 / 6306	995
175	5490	528	6199	995	6265 / 6306	995
180	5610	528	6319	995	6385 / 6426	995

88% MORE



NEW HOLLAND T7 - GAIN 76% MORE HEIGHT WITH HI-CROP

Model	UNMODIFIED		60" HI-CROP KIT	80" HI-CROP KIT	
	Weight	Clearance	Weight	Clearance	Clearance
165S	6700	565	Not currently available with the 60" track version	7516	995
175	6650	565		7466	995

76% MORE



CASE MAXXUM - GAIN 88% MORE HEIGHT WITH HI-CROP

Model	UNMODIFIED		60" HI-CROP KIT		72" / 80" HI-CROP KIT	
	Weight	Clearance	Weight	Clearance	Weight	Clearance
115	4890	528	5599	995	5665 / 5706	995
125	4890	528	5599	995	5665 / 5706	995
135	4890	528	5599	995	5665 / 5706	995
145	4890	528	5599	995	5665 / 5706	995
150	5020	528	5729	995	5795 / 5836	995

88% MORE



CASE PUMA - GAIN 76% MORE HEIGHT WITH HI-CROP

Model	UNMODIFIED		60" HI-CROP KIT	80" HI-CROP KIT	
	Weight	Clearance	Weight	Clearance	Clearance
140X	6840	565	Not currently available with the 60" track version	7656	995
150X	6840	565		7656	995
165X	6840	565		7656	995

76% MORE

Please note: Manufacturer data. All weights shown in Kg. All clearances shown in mm and measured from the ground to the lowest point across both axes. This measurement will be impacted by overall vehicle weight, ground conditions, tyre choices and tyre deformation.



RAISING YOUR BUSINESS

Hi-Crop offers real gains across your whole operation. Improving access, prolonging growth cycle and reducing operating costs is all possible with one modification.

Contact us for real-life profit case studies in your country.

We've been raising tractors for decades but we've also been lifting bottom-lines.

Hi-Crop adds more flexibility to your existing machinery, letting you get more out of what you put in the ground.

TOP HI-CROP BENEFITS

01



MARKET-LEADING CROP-CLEARANCE

Higher clearances mean taller plants and bigger crops. Our market-leading Hi-Crop system can add up to 18 months of growth to young plants and trees, allowing later harvests and better prices to improve your bottom line.

02



WE SUPPORT YOUR 'RIGHT TO REPAIR'

We agree that products should be built to have longer lifespans and be easier and more cost-effective to repair. You can't afford equipment downtime with costly service bills or lengthy maintenance tasks.

All our conversion kits are fully user-serviceable and sourcing parts direct from CountyTrac allows you to maintain your own vehicle, removing costly on-site inspections and unwanted travel to repair centres. You can minimise your machine's down time and arrange repairs when it suits your workload.

We provide digital part books and assembly sheets to all of our customers and our service and engineering teams are always ready to offer help and assistance.

03



EXCEPTIONAL CREEP SPEEDS

All of your work is made easier and more consistent with the advanced Hi-Crop system.

The innovative gear reduction ratios in our drop housings offer unstoppable pulling power and creep speeds as low as 0.09kph, yet will still reach 30kph for on-road travel. Reach new heights when protecting your crops through harvesting, cultivating and spraying.

04



USE SADDLE TANKS

By using drop housings with unequal sized front and rear wheels, all of our Hi-Crop conversion kits accommodate the use of saddle tanks. This ensures that both liquid fertiliser and Plant Protection Products (PPP) can be applied for longer throughout the crop's growth cycle.

05



FULL OEM WARRANTY

Hi-Crop won't impact any existing manufacturer warranty on your vehicle. We're so confident of our system that we provide a full 12-month Hi-Crop guarantee and will also assist with any claims on your vehicle for the full term of your cover.

COUNTYTRAC QUALITY

Hi-Crop is a precision engineered tractor modification that will help with access, growth and operating costs year on year.

FRONT DROP-HOUSING

Our unique steering knuckle fits your existing class-4 axle without further costly modifications.

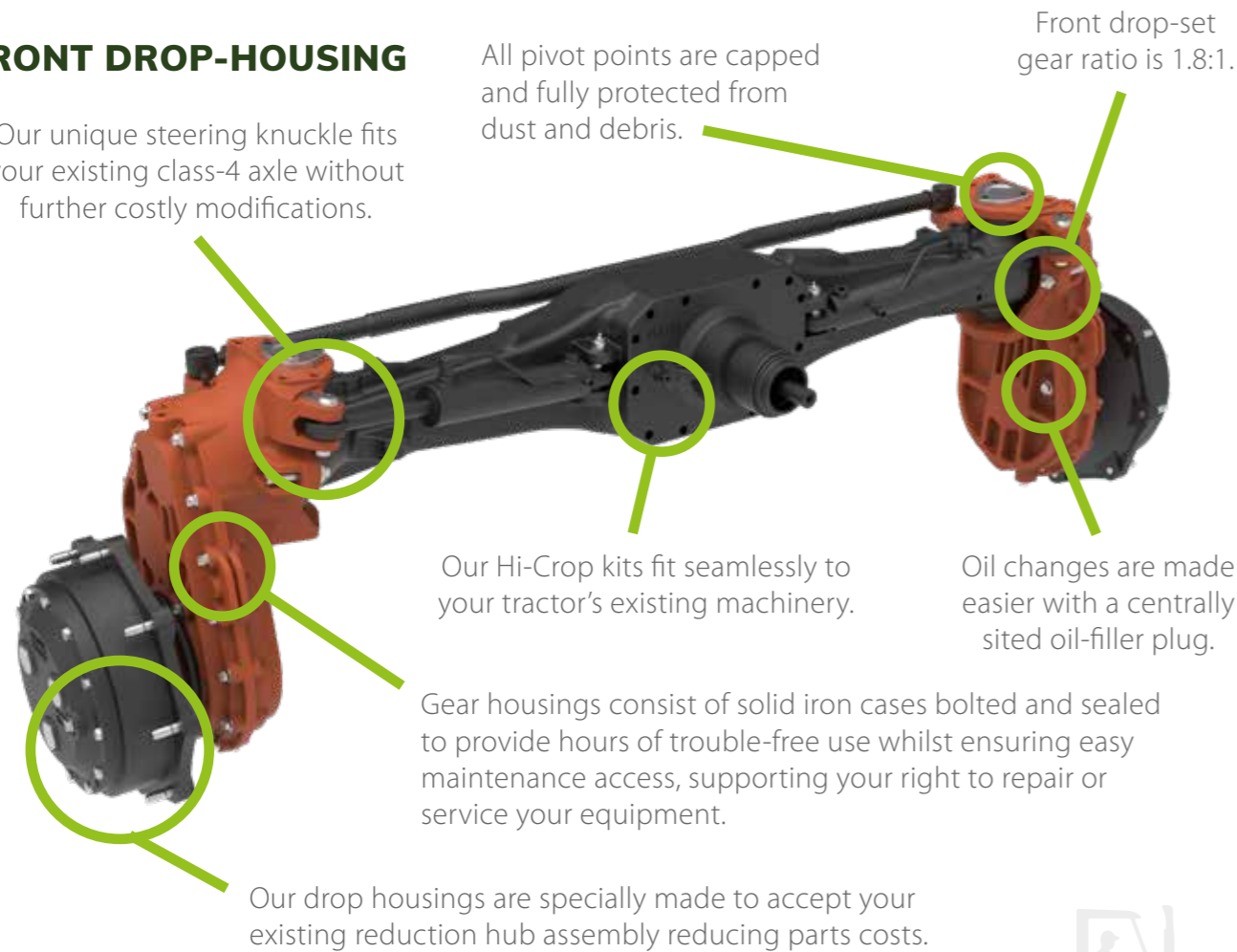

All pivot points are capped and fully protected from dust and debris.

Front drop-set gear ratio is 1.8:1.

Our Hi-Crop kits fit seamlessly to your tractor's existing machinery.

Oil changes are made easier with a centrally sited oil-filler plug.

Gear housings consist of solid iron cases bolted and sealed to provide hours of trouble-free use whilst ensuring easy maintenance access, supporting your right to repair or service your equipment.

Our drop housings are specially made to accept your existing reduction hub assembly reducing parts costs.



ULTIMATE USER CONVENIENCE

- Hi-Crop kits are supplied ready to install using only standard tools for ultimate convenience.
- All parts are red-oxide primed at our factory, ready for your choice of finishing paint.
- We ship everything 'clean and dry', allowing you to add your own preferred lubricant.
- To cater for all environments, Hi-Crop kits are designed to accept a variety of tyres and wheel sizes. We can provide full measurement data to facilitate all custom wheel orders.

REAR DROP-HOUSING

Optional extension couplings give a huge 72 / 80" track width.

Rear drop-set gear ratio is 1.66:1.

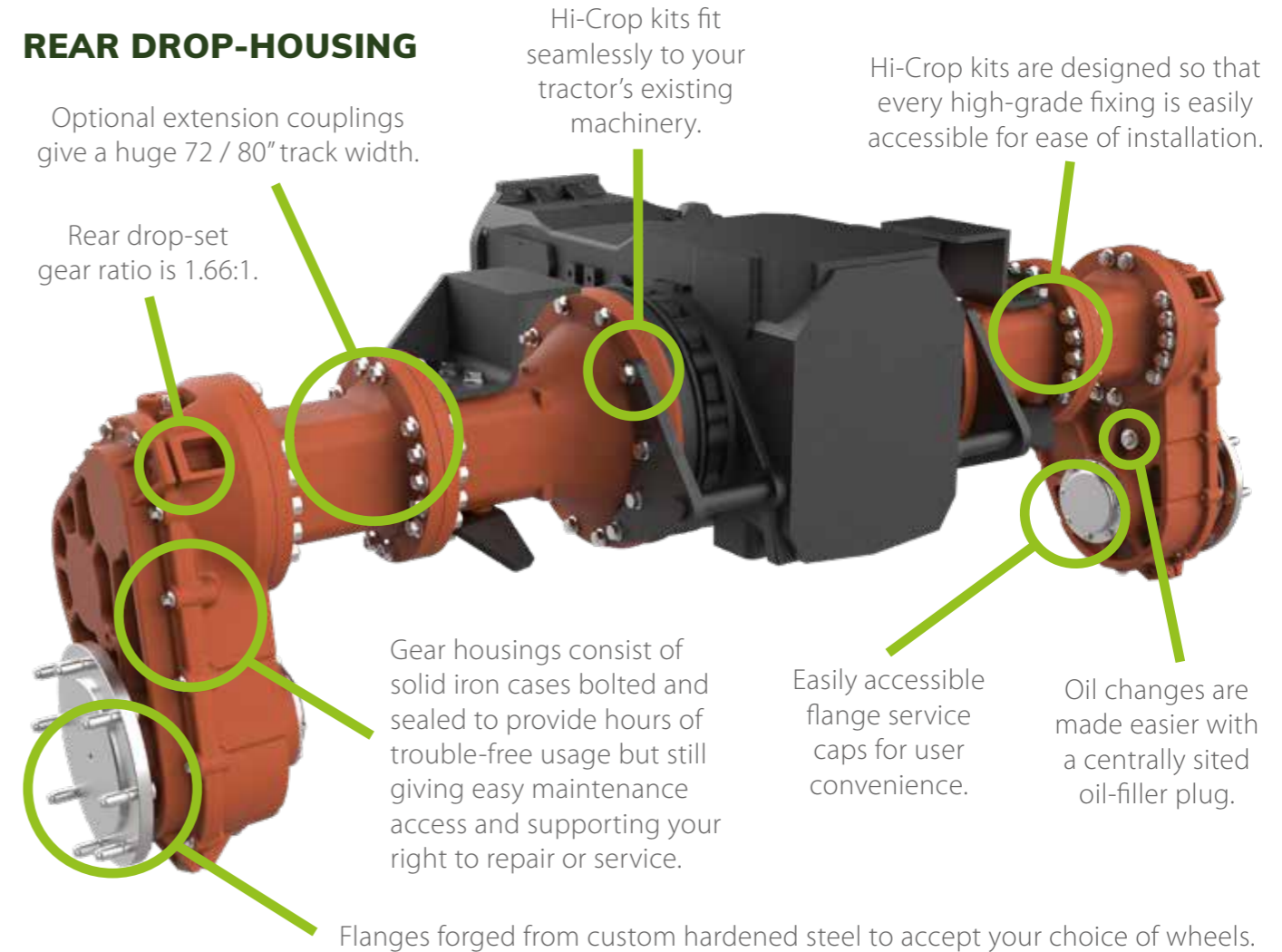

Hi-Crop kits fit seamlessly to your tractor's existing machinery.

Hi-Crop kits are designed so that every high-grade fixing is easily accessible for ease of installation.

Gear housings consist of solid iron cases bolted and sealed to provide hours of trouble-free usage but still giving easy maintenance access and supporting your right to repair or service.

Easily accessible flange service caps for user convenience.

Oil changes are made easier with a centrally sited oil-filler plug.

Flanges forged from custom hardened steel to accept your choice of wheels.

ADDITIONAL BENEFITS

- ✓ Full access to our comprehensive parts booklets and assembly guides.
- ✓ Technical data sheets and advanced modification options are available.
- ✓ Full 12-month assistive warranty and individual part replacements.
- ✓ Ongoing service support from our fully trained engineers with live help available over the phone, online or via email.

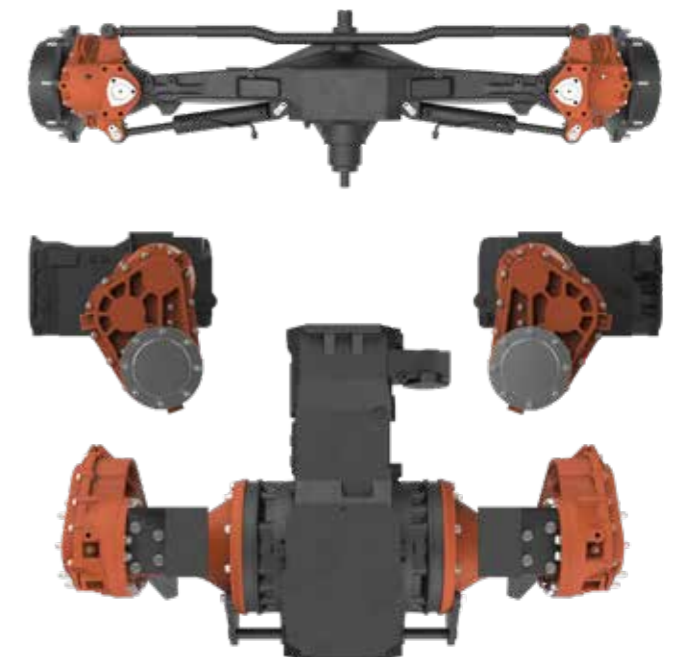

THE NEXT STEPS...

Ready to reach a little higher? Get in touch to discuss pricing options for your requirements and shipping destination.

VISIT US ONLINE

Our website is the best place for the latest information all of our Hi-Crop kits and other CountyTrac products.

➤ countytrac.com ➤ countyengineering.co.uk

CONTACT OUR DEDICATED SALES TEAM

Initial enquiries or full price breakdowns - our friendly and experienced team can provide all the information you need.

✉ sales@countyengineering.co.uk ☎ +44 (0)1233 622 214

SPEAK DIRECTLY TO OUR ENGINEERS

Our qualified engineers can help with any technical queries - just call, email or message the team. You can even video call us in real-time* to get expert advice on a problem that's difficult to describe or needs to be seen.

✉ engineering@countyengineering.co.uk

☎ +44 (0)1233 616 575 📞 +44 (0)7908 667 447

*Video calls may be subject to appointment during UK hours.



Hi-Crop conversion kits are designed and built in the UK and used by farmers all across the world.



Hi-Crop offers class-leading clearance for all kinds of ground conditions.

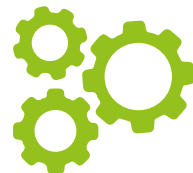

Our advanced gearing allows super-slow creep speeds of just 0.09kph.

More details online:

COUNTYTRAC.COM

Hi-Crop tractor conversions are manufactured in the UK by CountyTrac Limited, part of County, a subsidiary of the MJAllen Group.

Registered company number 845061. Registered address Cobbs Wood Industrial Estate, Ashford, Kent, TN23 1EW, UK.

All content © MJAllen Group or used under licence. All intellectual property rights are reserved.

Document version 4.0 | June 2022

